

SWITZERLAND



Kronoswiss

GRAND
SELECTION



Holz in Bestform • Wood at its best

 **SWISS KRONO**

GRAND SELECTION

DE Die Designs der GRAND SELECTION Produktlinien haben ein grosses Vorbild: den Naturholzboden. Und diesem Vorbild sehen sie verblüffend ähnlich. Doch noch mehr: Die Böden sind auch haptisch ein Erlebnis. Für alle Fussböden wird Holz verwendet, das aus nachhaltiger Forstwirtschaft stammt und in Schweizer Wäldern gewachsen ist. Das alles verspricht hochwertige Qualität und Langlebigkeit. Erfahren Sie mehr über das vielfältige Produktsortiment unter www.grand-selection.ch.

FR Les designs des gammes de produits GRAND SELECTION s'inspirent d'un modèle exemplaire: le parquet massif. Ils ressemblent d'ailleurs étonnamment à ce modèle. Le bois utilisé pour tous ces planchers provient de forêts suisses gérées de façon durable. Tous ces aspects sont les garants d'une qualité supérieure et d'une grande longévité. Pour en savoir plus sur la vaste gamme de produits, consultez le site www.grand-selection.ch.

IT I design delle linee di prodotti GRAND SELECTION hanno un esempio eccezionale a cui ispirarsi: il pavimento in legno naturale. E a questo sono veramente molto somiglianti. Ma ancora di più: i pavimenti rappresentano una piacevole esperienza anche al tatto. In tutti i pavimenti è usato legno originario proveniente da una silvicoltura sostenibile e cresciuto nei boschi della Svizzera. Tutto ciò garantisce qualità e durata di vita al massimo livello. Venite a scoprire nel dettaglio l'ampio assortimento di prodotti sul sito www.grand-selection.ch.

EN The designs of the GRAND SELECTION product ranges have a great role model: natural wood flooring. It looks amazingly similar to this role model too. There's more though: the floors are also an extra special experience as they are haptically wonderful. We only use wood which has grown in sustainable Swiss forests for all our floorings. All of this promises top quality and durability. Find out more about the diverse product range at www.grand-selection.ch.

ES Los diseños de las líneas de productos de GRAND SELECTION tienen un gran modelo: el suelo de madera natural. Y muestran un parecido asombroso con este modelo. Pero aún hay más: los suelos también proporcionan una experiencia háptica única. Para todos ellos se utiliza madera procedente de la silvicultura sostenible y crecida en bosques suizos. Todo ello es una promesa de gran calidad y durabilidad. Más información sobre el variado surtido de productos en www.grand-selection.ch.

PT Os designs das linhas de produtos GRAND SELECTION possuem um enorme modelo: os pavimentos naturais em madeira. E os produtos são espantosamente semelhantes a este modelo. Mas há ainda mais: os pavimentos são também uma experiência tátil. Em todos os pavimentos é utilizada madeira proveniente de uma silvicultura sustentável, cultivada em florestas suíças. Tal promete uma elevada qualidade e durabilidade. Saiba mais sobre a gama diversificada de produtos em www.grand-selection.ch.



OVERVIEW 4

GRAND SELECTION

ORIGIN 8

MONUMENTAL 14

OAK 18

WALNUT 24

GRAND FINISH 28

Profiles & Skirtings

PROVENT 29

Underlayment

INSTALLATION 30

CARE & MAINTENANCE 31

WARRANTY 34

TECHNICAL DATA 34

PACKING UNITS 35

OVERVIEW

GRAND FINISH

Profiles & Skirtings

- DE** Weitere Informationen auf Seite 28
- FR** Informations supplémentaires page 28
- IT** Altri informazioni a pagina 28
- EN** Further details on page 28
- ES** Informaciones adicionales en la página 28
- PT** Informações adicionais na pág. 28



PROVENT

Underlayment

- DE** Weitere Informationen auf Seite 29
- FR** Informations supplémentaires page 29
- IT** Altri informazioni a pagina 29
- EN** Further details on page 29
- ES** Informaciones adicionales en la página 29
- PT** Informações adicionais na pág. 29



BENEFITS

- DE** Übergrosse Paneelen für optische Highlights und schnelle Verlegung
- FR** Panneaux surdimensionnés pour un bel aspect visuel et une pose rapide
- IT** Pannelli extra grandi per creare accenti ottici e per una posa veloce
- EN** Oversize panels for visual highlights and quick installation
- ES** Paneles extragrandes para destacar elementos visualmente, de instalación rápida
- PT** Painéis sobredimensionados para destaques visuais e rápida instalação



- DE** Synchronporen-Struktur für eine authentische Echtholz-Wirkung
- FR** Structure synchrones pour effet bois véritable authentique
- IT** Struttura a pori rigistro per un autentico effetto del vero legno
- EN** Synchronised structure for an authentic real wood effect
- ES** Estructura de poros sincronizados para un efecto autentico de madera natural
- PT** Estrutura de poros sincronizados para um efeito autêntico de madeira natural

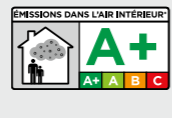
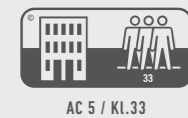
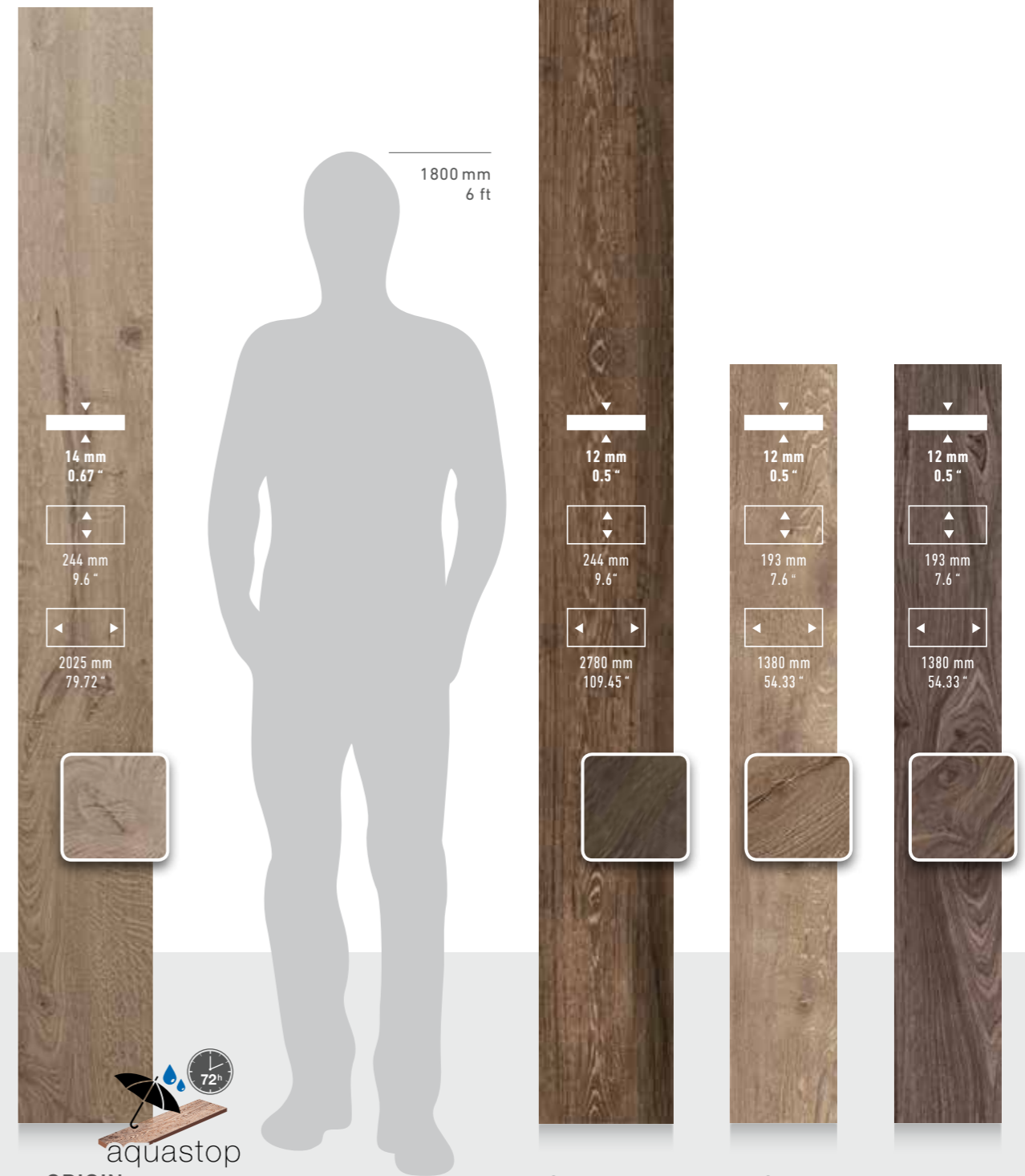

Fragen Sie nach FSC®-zertifizierten Produkten



ORIGIN
Page 8

MONUMENTAL
Page 14

OAK
Page 18

WALNUT
Page 24

DE

Attraktiv: GRAND SELECTION ist inzwischen in 23 einzigartigen Reproduktionen der faszinierendsten Eichen- und Walnuss-hölzer verfügbar. Es gibt vier Produktlinien und drei unterschiedliche Paneel-Formate. Das kann man mit Recht eine grossartige Auswahl nennen!

Innovativ: GRAND SELECTION sieht nicht nur aus wie ein wertvoller Massivholzboden, es fühlt sich auch so an. In Tiefe und exakter Abstimmung von Dekor und Struktur ist es unerreicht. Bei der Herstellung kommt neueste Technologie zum Einsatz und natürlich das berühmte Schweizer Qualitätsbewusstsein.

Wohngesund: GRAND SELECTION wird nach strengen europäischen Normen aus 100% natürlichen Rohstoffen hergestellt, hauptsächlich aus Holz. Die Emissionen sind die gleichen, die Sie auch von natürlichem, unbehandeltem Holz erwarten würden. Es ist ein Naturprodukt, das nach einer aktuellen Studie des renommierten Fraunhofer-Instituts keinerlei Gesundheitsrisiken mit sich bringt. Somit ist es für kleine Kinder und Haustiere besonders gut geeignet, die häufig und lange in direkten Kontakt mit dem Boden kommen.

FR

Séduisant: GRAND SELECTION est désormais disponible dans 23 imitations uniques et splendides de chêne et noyer proposées dans quatre gammes de produits et trois formats de planches. À n'en pas douter, un large choix disponible dans le monde entier!

Innovant: Il ressemble à s'y méprendre à un plancher en bois dur précieux – profondeur et précision inégalées pour une structure en harmonie avec le décor. Production avec la dernière technologie et conformément à la qualité suisse réputée dans le monde entier.

Sain: Produit selon les normes européennes les plus strictes. Pour une vie quotidienne saine, les émissions de vapeurs sont comparables à celles attendues pour du bois naturel. GRAND SELECTION se compose de matériaux 100% naturels, essentiellement du bois. Selon une récente étude du prestigieux Fraunhofer Institut, ce produit naturel ne présente aucun risque pour la santé. Il est donc particulièrement recommandé pour les jeunes enfants et les animaux domestiques, qui passent beaucoup de temps en contact avec le sol.

IT

Attrante: attualmente GRAND SELECTION è disponibile in 23 uniche riproduzioni dei più entusiasmanti modelli Oak e Walnut assortiti in quattro linee di produzione e tre diversi formati di doghe. Letteralmente una grandiosa selezione per tutti!

Innovativa: l'aspetto e la sensazione sono quelli di un prezioso pavimento in legno massiccio – impareggiabile per la profondità e la precisione del perfetto connubio di struttura e decoro. Prodotta con la tecnologia di ultima generazione e con la rinomata attenzione alla qualità svizzera.

Sana: prodotta in conformità alle più severe normative europee. Per una vita più sana, le emissioni di vapori corrispondono a quelle riscontrabili nel legno al naturale. GRAND SELECTION è costituita al 100% da materiali naturali, soprattutto legno. Questo prodotto naturale secondo un recente studio del prestigioso Istituto Fraunhofer non presenta alcun rischio per la salute. Quindi è particolarmente adatto a bambini ed animali, che trascorrono molto tempo a contatto con i pavimenti.

Ökologisch: Hergestellt aus nachhaltig bewirtschafteten Wäldern, wann immer möglich mit dem Label FSC® und aus lokalen Quellen. Produziert in der modernsten, umweltfreundlichsten Produktionsstätte ihrer Art.

Widerstandsfähig: Hervorragende Abriebfestigkeit (Klasse AC5/33), Kratz- und Stossfestigkeit, Farbechtheit (bleicht nicht aus) und Antistatik-Eigenschaften.

Preisgünstig: Unschlagbares Preis-/Leistungsverhältnis im Vergleich zu traditionellen Hartholzböden. Sie sparen nicht nur bei der Anschaffung, sondern auch später Zeit und Geld. Pflege und Instandhaltung sind ausgesprochen einfach. Es gibt kein Wachsen, Polieren und Schleifen, der Boden sieht noch nach Jahren aus wie am ersten Tag.

Écologique: Fabriqué avec bois de forêts gérées de manière durable. dans la mesure du possible, nous respectons les labels FSC®. Produit sur le site de production écologique le plus moderne du genre.

Résilient: Résistance supérieure à l'abrasion (cl. AC5/33), aux rayures et aux impacts, mais aussi résistance des couleurs (anti-décoloration) et propriétés anti-statiques.

Abordable: Rapport prix/performance imbattable comparé aux parquets en bois dur traditionnels: vous économisez à l'achat et réalisez aussi un gain de temps et d'argent par la suite. En effet, il est facile à entretenir et à réparer. Inutile de le cirer, de le poncer ou de le sabler, il conservera son aspect pendant de nombreuses années.

Ecologica: fatto al legno esclusivamente da foreste a gestione sostenibile. Ogni qualvolta possibile, ci assicuriamo della presenza delle relative certificazioni di sostenibilità FSC®. Prodotto presso lo stabilimento più moderno ed ecologico del suo genere.

Resistente: resistenza superiore all'abrasione (cl. AC5/33), ai graffi e agli impatti, presenta proprietà di inalterabilità del colore (anti-decolorazione) e antistatiche.

Economica: rapporto qualità/prezzo imbattibile rispetto ai pavimenti in legno massiccio tradizionali: il risparmio è evidente non soltanto al momento dell'acquisto del pavimento, ma anche successivamente in termini di tempo e denaro. Il pavimento richiede pochissimi interventi di manutenzione ed è facile da pulire. Non occorre passare la cera, lucidare o sottoporre a sabbiatura, il pavimento si manterrà in perfette condizioni per anni e anni, come il giorno della posa.

EN

Attractive: Meanwhile GRAND SELECTION is available in 23 unique reproductions of the most exciting oak and walnut decors assorted in four product lines and three different plank formats. Literally a grand selection for all the world!

Innovative: Looks and feels like a precious hardwood floor – unrivalled in depth and precision of how the structure meets perfectly with the decor. Produced with the latest technology as well as the famous Swiss Quality awarness.

Healthy: Produced to strict European Standards. For a healthy living, emissions are the same as you would expect from wood in its natural state. GRAND SELECTION is made of 100% natural materials, mainly wood. This natural product, which according to a recent survey by the prestigious Fraunhofer Institut poses no risk to health. This makes it particularly suitable for young children and pets, who spend a lot of time in contact with the floor.

ES

Atractivo: GRAND SELECTION está disponible ya en 23 reproducciones distintas de los robles y nogales más bellos, organizados en cuatro líneas de productos y tres formatos de panel distintos. ¡Se trata literalmente de una gran selección para todo el mundo!

Innovador: Tiene la apariencia y el tacto de un valioso suelo de madera dura – sin rival en cuanto a profundidad y precisión de coincidencia perfecta entre el decorado y la veta. Producido con la más moderna tecnología y aplicando el famoso sentido de la calidad suizo.

Saludable: Fabricado en conformidad con estrictas normas europeas. Para un hogar saludable, las emisiones de componentes volátiles son las mismas que usted podría esperar de la madera natural. GRAND SELECTION está fabricado al 100% con materiales naturales, principalmente madera. Se trata de un producto natural, que según un estudio reciente realizado por el prestigioso Fraunhofer Institut no representa riesgo alguno para la salud. Esto lo hace especialmente adecuado para niños pequeños y animales domésticos, que pasan mucho tiempo en contacto con el pavimento.

PT

Atrativo: Enquanto isso, a GRAND SELECTION está disponível em 23 reproduções únicas de carvalho e nogueira, em quatro linhas de produtos e três formatos diferentes de réguas. Literalmente, uma grande seleção para todo o mundo!

Inovador: Pavimento de madeira de qualidade superior, tanto no aspeto como na perceção – incomparável na forma como a estrutura casa bem com o padrão da madeira. Produzido com tecnologia de ponta, bem como com a renomada perceção da qualidade suíça.

Saudável: Produzido segundo as rigorosas normas europeias. Para uma vida saudável, as emissões de vapores são as mesmas esperadas da madeira no seu estado natural. GRAND SELECTION é 100% feito de materiais naturais, especialmente madeira. De acordo um recente estudo do prestigiado Instituto Fraunhofer este produto natural não representa qualquer risco para a saúde. Esse facto torna-o particularmente adequado para crianças e animais de estimação, que passam muito tempo em contato com o chão.

Ecological: Made of wood from sustainably managed forests and whenever possible we look for the relevant FSC® certificates. Produced at the most modern, environmental friendly production facility of its kind.

Resilient: Superior abrasion (cl. AC5/33), scratch- and impact resistance as well as colourfast (anti-fade) and anti-static properties.

Affordable: Unbeatable price/performance ratio compared to traditional hard wood floors: You not only save initially when buying the floor but again later on in both money and time. It is a low maintenance and easy to care flooring. There is no need to wax, polish or sanding it, and it stays looking like the day you laid it for years and years.

Ecológico: Fabricado de bosques gestionados de forma sostenible siempre que sea posible con la etiqueta FSC® de recursos locales. Producido en las instalaciones más modernas y respetuosas con el medio ambiente de su clase.

Resiliente: Resistencia a la abrasión (cl. AC5/33), a los arañazos y a los impactos superior, así como con propiedades de solidez de color (resistentes a la decoloración) y antiestáticas.

Económico: Relación calidad-precio imbatible en comparación con los pavimentos tradicionales de madera dura: no sólo representa para usted un ahorro inicial al adquirir el pavimento, sino también posteriormente, tanto en tiempo como en dinero. Se trata de un pavimento de mantenimiento reducido y fácil de cuidar. No necesitará encerarlo, pulirlo, ni lijarlo y conservará durante años y años el mismo aspecto que cuando lo colocó.

Ecológico: Proveniente de florestas geridas de forma sustentável, sempre que possível com o rótulo FSC®, de recursos locais. Produzida nas instalações mais modernas e ambientalmente adequadas do género.

Resiliente: Abrasão superior (cl. AC5/33), resistência a riscos e ao impacto, bem como propriedades antiesbatimento e antiestática.

Economico: Relação qualidade/preço imbatível, comparada com pavimentos de madeira dura tradicionais: Irá poupar tempo e dinheiro não só aquando da compra do pavimento, mas também mais tarde. Trata-se de um pavimento de baixa manutenção de fácil tratamento. Não há necessidade de encerar, polir ou lixar: durante anos e anos, o aspeto será o mesmo do dia em que foi aplicado.

GRAND SELECTION ORIGIN

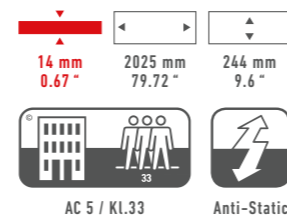

DE 14 mm GRAND SELECTION ORIGIN ist seinem Vorbild, massivem und rustikalem Echtholz, so gut nachempfunden, dass auch Kenner sehr genau hinsehen müssen, um den Unterschied zu erkennen.

FR Même les connaisseurs auront du mal à distinguer les parquets solides et rustiques en bois véritable du GRAND SELECTION ORIGIN 14 mm.

IT L'imitazione del solido pavimento rustico in vero legno rende ormai quasi impossibile anche agli intenditori distinguere il laminato da 14 mm GRAND SELECTION ORIGIN.

EN Based on the solid, rustic floor of real wood, the 14 mm GRAND SELECTION ORIGIN resembles the original so close that even experts hardly can tell the difference.

ES GRAND SELECTION ORIGIN, de 14 mm de espesor, reproduce una sólida tarima rústica de madera auténtica de tal forma, que ni siquiera un experto es apenas capaz de distinguirla.

PT GRAND SELECTION ORIGIN de 14 mm de espessura, reproduz um pavimento genuíno de madeira sólida e rústica, dificilmente distinguível mesmo pelos melhores conhecedores.



IMAGINE WHAT THIS FLOOR
COULD DO FOR YOUR HOME.

D 4493 CM

FOR THE ULTIMATE PIECE OF MIND



DE Der 72-Stunden Feuchteschutz vor Zwischenfällen im Haushalt mit Wasser und kleineren «Unfällen» von Haustieren.

FR Une protection de 72h contre les incidents liquides domestiques et les «accidents» de nos amis les bêtes.

IT Protezione per 72 ore contro le fuoriuscite domestiche e sporcizia causati da animali domestici.

EN The 72 h protection against everyday household spills and pet messes.

ES Protección durante 72 horas contra derrames y suciedad causada por animales domesticos.

PT Proteção durante 72 horas contra derramamentos domésticos e sujidade provocada por animais de estimação.

Visit for details swisskrono.ch



NATURAL RESSOURCES



CHILD & PET FRIENDLY



WET MOPPABLE

AQUASTOPBENEFITS

GRAND SELECTION
ORIGIN

SNOW
D 4494 CM



MOON
D 4498 CM



ROCK
D 4496 CM



BEACH
D 4492 CM



GRAND SELECTION
ORIGIN

SUNSHINE
D 4495 CM



TERRA
D 4497 CM



SUNSET
D 4493 CM



VOLCANO
D 4499 CM



GRAND SELECTION MONUMENTAL

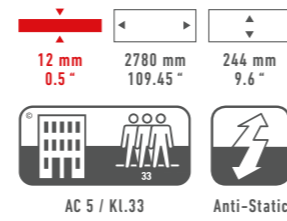

DE GRAND SELECTION MONUMENTAL überzeugt mit eleganter Schönheit auf 2780 mm Länge.

FR GRAND SELECTION MONUMENTAL convainc par son élégance en 2780 mm de longueur.

IT GRAND SELECTION MONUMENTAL intriga per l'elegante bellezza dei suoi 2780 mm di lunghezza.

EN GRAND SELECTION MONUMENTAL convinces with elegant beauty over a length of 2780 mm / 9 feet (exact 9.12).

ES GRAND SELECTION MONUMENTAL convence por su belleza legante, repartida sobre sus 2780 mm de longitud.

PT GRAND SELECTION MONUMENTAL convence pela elegância da ua beleza em 2780 mm de comprimento.



ISABELLINE
D 4191 CR



SAND
D 4196 CR



IMAGINE WHAT THIS FLOOR
COULD DO FOR YOUR HOME.

D 3740 CR

GRAND SELECTION
MONUMENTAL

LION
D 4198 CR



CHOCO
D 3740 CR



HONEY
D 3739 CR



GRAND SELECTION OAK

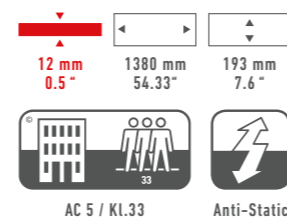

DE Die GRAND SELECTION OAK Linie bietet klassische Eleganz in zehn vielfältigen Farbvarianten.

FR La gamme GRAND SELECTION OAK offre une élégance classique dans une variété de dix coloris.

IT La linea GRAND SELECTION OAK offre un'eleganza classica in dieci diverse colori.

EN The GRAND SELECTION OAK line offers classical elegance in ten various colours.

ES La línea GRAND SELECTION OAK ofrece elegancia clásica en decena variantes de color distintas.

PT A linha GRAND SELECTION OAK oferece elegância clássica em dez cores distintas.

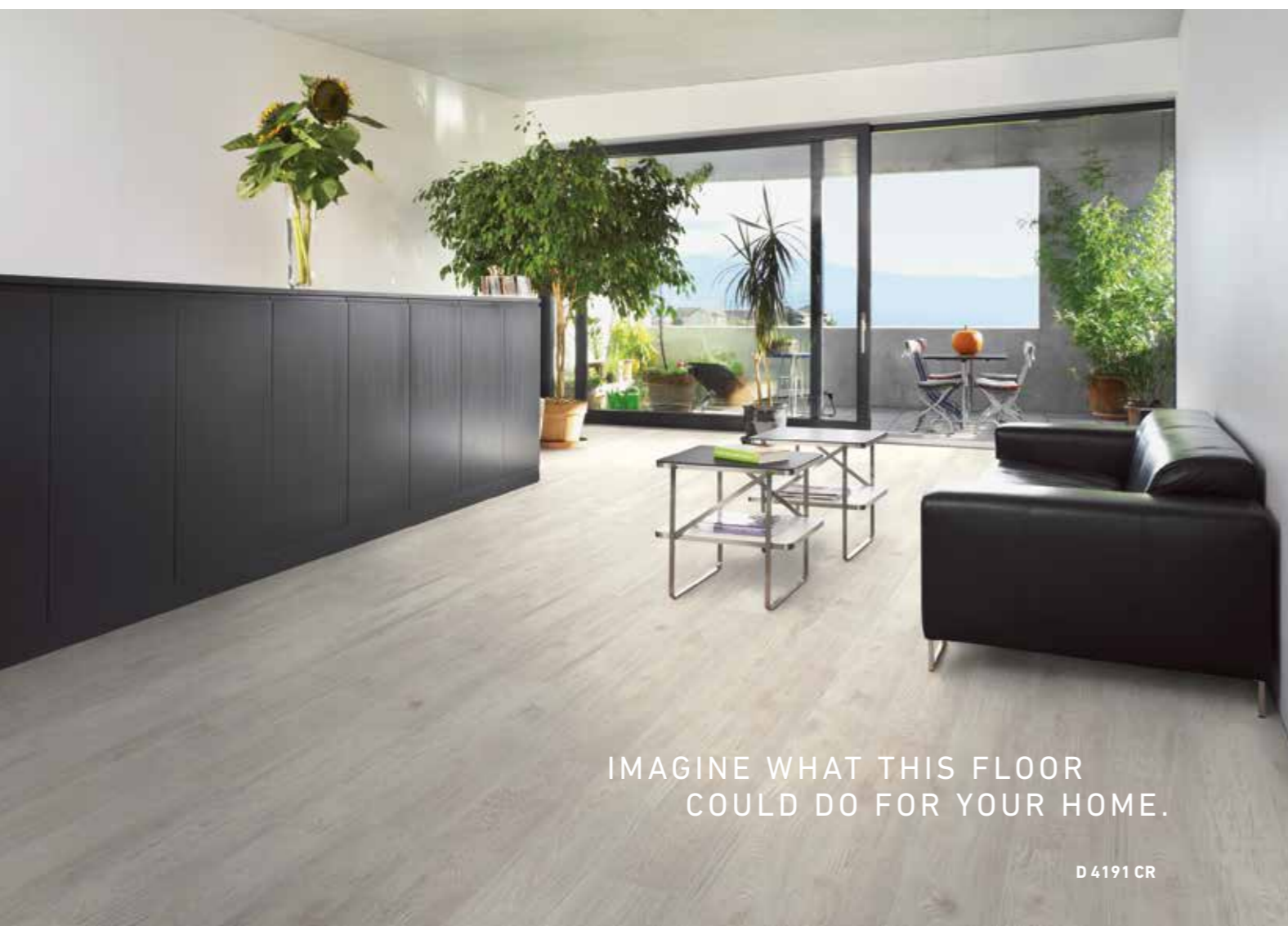

IMAGINE WHAT THIS FLOOR
COULD DO FOR YOUR HOME.

D 4191 CR

ISABELLINE
D 4191 CR



SAND
D 4196 CR



GRAND SELECTION
OAK

TAN
D 4193 CR



ECRU
D 4192 CR



LION
D 4198 CR



CAMEL
D 4194 CR



GRAND SELECTION
OAK

HONEY
D 3739 CR



CHOCO
D 3740 CR



BEAVER
D 4190 CR



UMBER
D 4197 CR



GRAND SELECTION WALNUT

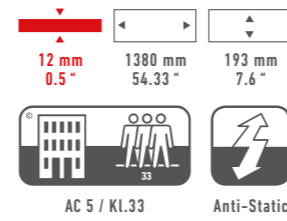

DE Rustikale Holzoptik in warmen Farbtönen für pure Harmonie und Natürlichkeit, dafür steht GRAND SELECTION WALNUT.

FR Un aspect bois rustique dans des tons chauds pour une ambiance naturelle toute en harmonie, voici ce qu'offre la gamme GRAND SELECTION WALNUT.

IT L'aspetto rustico del legno nelle calde tonalità di colore di GRAND SELECTION WALNUT è sinonimo di armonia e naturalezza allo stato puro.

EN Look of rustic wood in warm colours for pure harmony and naturalness, this is what GRAND SELECTION WALNUT stands for.

ES Acabado de madera rústica, en tonos cálidos, para una armonía y naturalidad puras: esto es lo que representa GRAND SELECTION WALNUT.

PT Aspeto rústico em tonalidades quentes, para a mais pura harmonia e naturalidade – é esse o mote da GRAND SELECTION WALNUT.



IMAGINE WHAT THIS FLOOR
COULD DO FOR YOUR HOME.

D 3214 CR

BEIGE
D 3213 CR



BRONZE
D 3214 CR



GRAND SELECTION
WALNUT

CHAMOISEE
D 3215 CR



SEPIA
D 3217 CR



RUSSET
D 3216 CR



GRAND FINISH

Profiles & Skirtings

2400 mm
94.5"

Viertelstab

Quart de rond | Quadrotto | Quarterround |
Junquillo remate | Quadrante

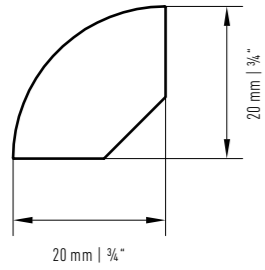

Übergangprofil

Seuil de transition | Profi lo di transizione | Transition profile |
Junta de dilatación | Perfil de transição

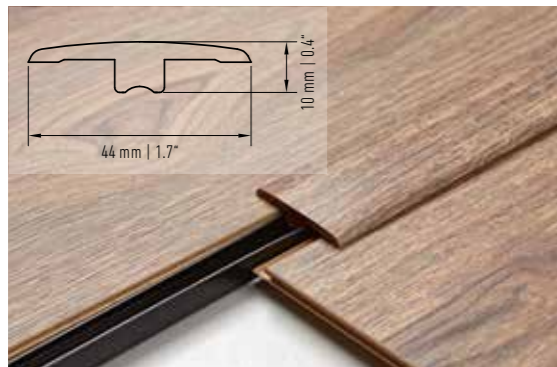

AC 5 / Kl.33

Treppenkante

Nez de marche | Profi lo per scale | Stairnose |
Perfil de escalera | Perfil de degrau

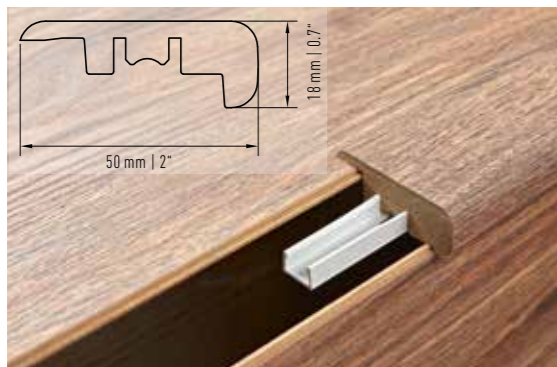

AC 5 / Kl.33

Sockelleiste

Plinthe | Battiscopa | Skirting board | Rodapié | Rodapé

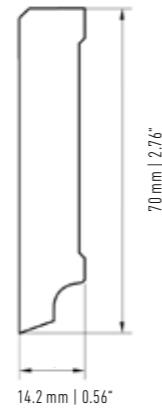

Ausgleichsprofil

Seuil d'galisation | Profi lo di compensazione | Reducer |
Junta de transición | Perfil de dilatação

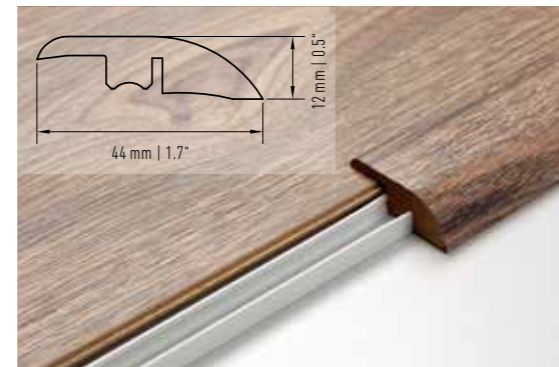

AC 5 / Kl.33

PROVENT

Underlayment

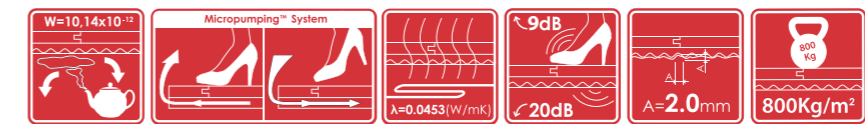
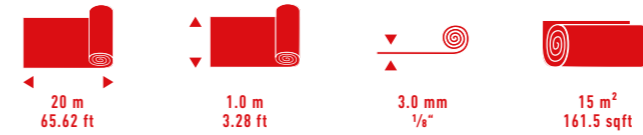

DE PE Unterlage mit integrierter Feuchtigkeitsbremse und Zirkulationsrillen (Micropumping System). Unterstützt die Luftzirkulation unter dem Boden und verhindert Schimmelbildung..

EN PE underlay with integrated moisture barrier and circulation grooves (micropumping system). Supports the circulation of air under the floor and prevents the formation of mould.

FR Sous-couche PE avec système stop humidité intégré et rainures de circulation (Micropumping System) Assiste la circulation de l'air sous le sol empêchant la formation de moisissures.

ES Base de PE con barrera antihumedad integrada y ranuras de circulación (Micropumping System). Favorece la circulación del aire debajo del suelo y previene la formación de moho.

IT Supporto PE con barriera antiumidità in PE e scanalature di circolazione (sistema Micropumping). Favorisce la circolazione dell'aria sotto il pavimento impedendo la formazione di muff.

PT Base de PE com barreira antihumidade integrada e canais de ventilação (Micropumping System). Favorece a circulação de ar debaixo do pavimento e serve com prevenção da formação de mofo..

INSTALLATION

DE Das 5G-Klicksystem ist eines der fortschrittlichsten Verbindungssysteme auf dem Markt. Es ist die schnellste und leichteste Methode, Laminat zu verlegen. Das Geheimnis liegt in einer herausnehmbaren Glasfaser-Feder an der schmalen Seite der Paneele. Das Einrasten geschieht automatisch, wenn das Paneel nach unten geschwenkt wird.

Weitere Informationen: www.grand-selection.ch

FR Le système de pose 5G est l'un des plus avancés du marché. C'est la méthode la plus facile et la plus rapide pour installer des sols stratifiés. Son secret est un ressort amovible en fibre de verre sur le côté court du panneau. Le verrouillage est activé par un simple mouvement de pliage vers le bas.

Informations supplémentaires: www.grand-selection.ch

IT Il sistema di giunzione 5G è uno tra i più avanzati sistemi di giunzione sul mercato, se non addirittura il più innovativo di tutti. È contemporaneamente il metodo più veloce e facile di installare le pavimentazioni in laminato. Il segreto è una molla in fibra di vetro amovibile sul lato corto del pannello. Il sistema di blocco viene attivato da un semplice movimento di ribaltamento in basso.

Altri informazioni: www.grand-selection.ch

EN The 5G connection is one, if not the most advanced click system on the market. It is simultaneously the fastest and easiest method to install laminate flooring. The secret is a removable fibreglass tongue on the short side of the panel. The locking method is activated by a simple folding down motion.

Further information: www.grand-selection.ch

ES La conexión 5G es uno de los más avanzados – si no el más avanzado – sistemas de conexión del mercado. Es el método más rápido y, al mismo tiempo, fácil para instalar un laminado. Su secreto reside en un resorte de fibra de vidrio desmontable en el lado corto de la lama. El sistema de enclavamiento queda activado mediante un sencillo movimiento de giro de bajada.

Informaciones adicionales: www.grand-selection.ch

PT O Sistema de Encaixe 5G é talvez o mais avançado no mercado. É o método mais rápido e mais fácil de instalar pavimentos laminados. O segredo é uma fibra de vidro amovível no lado curto do painel. O método de bloqueio é ativado por um simples movimento para baixo.

Informação adicional: www.grand-selection.ch

CARE & MAINTENANCE

DE GRAND SELECTION Laminatfußböden sind sehr pflegeleicht. Sie brauchen weder spezielle Reinigungsmittel noch irgendwelche Nachbehandlungen. Staubsaugen oder gelegentliches feucht Aufwischen genügt vollkommen. Dies spart nicht nur Zeit und Geld, sondern auch den Einsatz von Chemikalien im Haushalt.

Obwohl Laminatfußböden sehr widerstandsfähig sind, sind sie doch nicht unzerstörbar. Folgende einfachen Vorkehrungen bewahren den Laminatfußboden vor Kratzern und anderen Beschädigungen:

- Sauberlaufzonen, Schmutzfangmatten im Eingangsbereich verwenden
- Schmutz, Sand, Steinchen und andere Fremdkörper rasch entfernen
- Möbel, insbesondere Stühle, mit Filzgleitern ausrüsten
- Verschüttete Flüssigkeiten sofort aufwischen
- Bürostühle mit weichen Rollen, ggf. Schutzfolien verwenden

Regelmässige Reinigung

- Boden mit Besen, besser Staubtuch von loseem Staub befreien
- Staubsaugen mit einer Bodendüse mit weichen Bürsten
- Bei Bedarf gelegentlich mit einem gut ausgewrungenen, nebelfeuchten Tuch wischen und nachtrocknen. Klares Wasser ohne Zusätze genügt.

Nicht geeignet

- Dampfreiniger
- Nasses Aufwischen
- Politur, Wachs, Öl, Lack, etc. Diese können sich nicht mit der Melaminoberfläche verbinden und können unerwünschte Veränderungen hervorrufen.
- Säuren
- Abrasiv wirkende Reinigungsmittel, Schwämme, Tücher, Pads etc.
- Abschleifen

Weitere Hinweise unter www.epfl.com/infomaterial

FR Les sols stratifiés GRAND SELECTION sont très faciles à entretenir. Ils ne nécessitent ni produits de nettoyage, ni traitements spéciaux. Il suffit de passer l'aspirateur ou, occasionnellement, la serpillère. Cela représente un gain de temps et d'argent et permet de limiter l'utilisation de produits chimiques dans la maison.

Bien que les sols stratifiés soient très résistants, ils ne sont pas indestructibles. Les mesures suivantes sont simples et préviennent les rayures et autres dommages:

- Utiliser des tapis et paillassons dans l'entrée
- Éliminer rapidement la saleté, le sable, les gravillons et autres corps étrangers
- Équiper les meubles, et en particulier les chaises, de patins en feutre
- Essuyer immédiatement tout liquide renversé
- Utiliser des fauteuils de bureau avec des roulettes souples ou un film de protection

Nettoyage régulier

- Éliminer la poussière à l'aide d'un balai ou, de préférence, d'un chiffon
- Aspirer avec une brosse à poils souples
- Si nécessaire, laver occasionnellement avec un chiffon bien essoré, puis sécher. De l'eau claire sans additif suffit.

Méthodes inappropriées

- Nettoyeur à vapeur
- Lavage à grande eau
- Polissage, cirage, huilage, peinture, etc. ces méthodes sont incompatibles avec la surface stratifiées et peuvent entraîner des modifications indésirables.
- Acides
- Produits de nettoyage, éponges, chiffons, lingettes, etc. abrasifs
- Ponçage

Pour plus de conseils, consultez le site www.epfl.com/infomaterial

IT I pavimenti in laminato di GRAND SELECTION sono di facile manutenzione. Non necessitano né di detergenti speciali né di qualsivoglia post-trattamento. È più che sufficiente passare l'aspirapolvere oppure di tanto in tanto lo straccio umido. Così non si risparmia solo su tempo e denaro, ma anche sull'impiego di sostanze chimiche durante i lavori domestici.

Benché i pavimenti in laminato siano molto resistenti, non sono comunque indistruttibili. Le seguenti misure di facile applicazione preservano il pavimento in laminato da graffi ed altri danni:

- ricorrere ad aree destinate alla pulizia e zerbini negli ingressi
- rimuovere con rapidità sporco, sabbia, sassolini ed altri corpi estranei
- dotare i mobili, in particolare le sedie, di feltrini
- asciugare subito con uno straccio liquido rovesciati sul pavimento
- utilizzare sedie da ufficio con ruote morbide, eventualmente con pellicole protettive

Pulizia regolare

- rimuovere dal pavimento la polvere sparsa con la scopa, meglio ancora con un panno antipolvere
- aspirare la polvere con una bocchetta per pavimenti con spazzole morbide
- quando necessario, passare uno straccio umido ben strizzato e lasciar asciugare. È sufficiente acqua pulita senza alcun additivo.

Non sono idonei

- pulitori a vapore
- pulizia con stracci bagnati
- lucidatura, cera, olio, vernice, ecc., che non si legano alla superficie melaminica e possono provocare indesiderate alterazioni.
- acidi
- detergenti, spugne, panni, dischi ad azione abrasiva ecc.
- abrasione

Per ulteriori avvertenze consultare www.eplf.com/infomaterial

EN GRAND SELECTION laminate floors are very easy to care for. They need neither special cleaning agents nor any other subsequent treatment. A vacuum cleaner or the occasional moist mop is perfectly adequate. This saves not only time and money, but also the use of chemicals in the household.

Although laminate floors are highly resistant, they are not indestructible. The following simple precautions protect the laminate floor from scratches and other damage:

- Use cleanwalk zones and dirt absorbing mats in the entrance area
- Quickly remove all dirt, sand, grit, and other foreign bodies
- Fit furniture, and especially chairs with felt pads
- Immediately wipe up spilled liquids
- Use office chairs with soft casters or on protective mats

Regular cleaning

- Remove loose dust from the floor with a broom, or better with a duster
- Vacuum clean with a floor nozzle fitted with soft brushes
- When necessary, wipe occasionally with a well wrung, wet sprayed cloth, and dry afterwards. Clean water without additives is adequate.

Not suitable

- Steam cleaners
- Wet mopping
- Polish, wax, oil, paint, etc. These cannot bond to the melamine surface and can give rise to undesired changes.
- Acids
- Abrasive cleaning agents, sponges, cloths, pads, etc.
- Sanding

Further information at www.eplf.com/infomaterial

ES Los laminados GRAND SELECTION requieren muy pocos cuidados. No necesitan productos de limpieza ni tratamientos posteriores especiales. Basta con aspirarlos o limpiarlos ocasionalmente en húmedo. Esto no sólo permite ahorrar tiempo y dinero, sino que evita también el uso de productos químicos en el hogar.

A pesar de que los laminados son muy resistentes, no son indestructibles. Las sencillas medidas siguientes protegen los laminados de los arañazos y otros daños:

- Crear zonas de limpieza y colocar felpudos antisuciedad en la zona de acceso
- Retirar rápidamente la suciedad, la arena, las piedrecitas y otros cuerpos extraños
- Aplicar fieltros protectores en los muebles, especialmente en las sillas
- Recoger inmediatamente los líquidos derramados
- Utilizar sillas de oficina con ruedas blandas; en caso necesario utilizar esterillas protectoras

Limpieza periódica

- Eliminar el polvo suelto con una escoba o, mejor, con un paño recogepolvo
- Aspirar con un suplemento para suelo provisto de cepillos suaves
- En caso necesario pasar una bayeta bien escurrida y secar a continuación. Basta con utilizar agua limpia sin más.

No son adecuados

- Los limpiadores de vapor
- Fregar con agua
- Los pulimentos, la cera, el aceite, los barnices, etc., porque pueden anclarse en la superficie de melamina y provocar alteraciones no deseadas en la misma.
- Los ácidos
- Los productos de limpieza, esponjas, bayetas, pads, etc. con efecto abrasivo
- El lijado

Vea más indicaciones bajo www.eplf.com/infomaterial

PT Pavimentos laminados GRAND SELECTION são de fácil tratamento. Não necessitam detergentes especiais nem de quaisquer tratamentos a posterior. Basta aspirar ou limpar com esfregona húmida. Isso não só economiza tempo e dinheiro como também o uso de produtos químicos dentro de casa.

Apesar dos pavimentos laminados serem muito resistentes, não são indestrutíveis. As seguintes precauções simples preservam os pavimentos laminados de arranhões e outros danos:

- Use tapetes e esteiras na área de entrada
- Remova rapidamente sujidade, areia, pedras e outros detritos
- Aplique películas protetoras nas bases dos móveis, especialmente das cadeiras
- Limpe imediatamente quaisquer líquidos
- Use cadeiras de escritório com rodas macias, eventualmente use películas protetoras

Limpeza regular

- Limpe poeiras soltas do pavimento com uma vassoura ou um pano de pó
- aspire com um bocal para pavimentos com escovas macias
- Se necessário, limpe e seque ocasionalmente com um pano húmido e bem torcido. Basta água limpa sem aditivos.

Não indicado

- Limpadores de vapor
- Limpeza húmida
- Polimento, cera, óleo, verniz, etc., podem não se ligar à superfície de melamina e causar alterações indesejadas.
- Ácidos
- Detergentes abrasivos, esponjas, panos, esfregões, etc.
- Abrasagem

Mais informação em www.eplf.com/infomaterial

WARRANTY

DE SWISS KRONO AG gewährt Käufern von GRAND SELECTION Laminat eine zusätzliche Garantie auf die Abriebfestigkeit der Oberfläche. Die Garantie gilt ab Kaufdatum und unter Massgabe weiterer Bestimmungen. Ihre normalen gesetzlichen Rechte sind davon nicht betroffen. Die vollständigen Garantiebestimmungen finden Sie unter:

www.swisskrono.ch/produkte/fussboden/garantie

FR SWISS KRONO AG accorde aux acquéreurs de sols stratifiés GRAND SELECTION une garantie supplémentaire sur la résistance à l'abrasion de la surface, valide à compter de la date d'achat. Cette garantie est conforme aux dispositions. Vos droits prévus par la loi ne sont pas affectés. Pour plus de détails sur la garantie, consultez le site:

www.swisskrono.ch/fr/produits/elements-de-sol/garantie

IT SWISS KRONO AG concede agli acquirenti di pavimenti in laminato GRAND SELECTION una garanzia supplementare, con validità a decorrere dalla data di acquisto, sulla resistenza alle abrasioni della superficie. La garanzia è conforme alle disposizioni, senza alcun pregiudizio per i vostri normali diritti di legge. Per un quadro completo dei dettagli della garanzia si prega di visitare:

www.swisskrono.ch/it/prodotti/pavimenti-in-laminato/la-vostra-garanzia

EN SWISS KRONO AG grants to purchasers of GRAND SELECTION laminate flooring, valid from date of purchase, an additional warranty on the abrasion resistance of the surface. This warranty is in accordance with provisions. Your normal statutory rights are not affected. For full warranty details please visit:

www.swisskrono.ch/en/products/flooring/your-guarantee

ES SWISS KRONO AG concede a los compradores del laminado GRAND SELECTION una garantía adicional sobre la resistencia a la abrasión de la superficie, válida a partir de la fecha de la compra. Dicha garantía está sujeta a unas condiciones. Sus derechos legales normales no se ven afectados por la misma. Vea los detalles completos de la garantía yendo a:

www.swisskrono.ch/es/productos/suelos/garantia

PT SWISS KRONO AG concede aos compradores do pavimento laminado GRAND SELECTION, a partir da data de compra, uma garantia adicional sobre a resistência da superfície à abrasão. Esta garantia está sujeita a condições e os direitos legais normais não são afetados. Para detalhes completos da garantia, por favor, visite:

www.swisskrono.ch/pt/producos/pavimentos/garantia

TECHNICAL DATA

DE Angaben zu den Technischen Daten finden Sie auf unserer Webseite www.grand-selection.ch

FR Vous trouverez des indications relatives aux données techniques sur notre site Web www.grand-selection.ch

IT Troverete indicazioni sui dati tecnici attraverso il nostro sito del web www.grand-selection.ch

EN Technical details can be found on our website www.grand-selection.ch

ES Vea informaciones sobre los datos técnicos en nuestro sitio web www.grand-selection.ch

PT Informações sobre os dados técnicos podem ser consultadas no nosso site www.grand-selection.ch

PACKING UNITS

ORIGIN



1 Box = 3 Paneelen = 1.48 m² / 19 kg
1 box = 3 panels = 15.96 sqft / 41.89 pounds



45 Boxen = 66.7 m² / 960 kg
45 boxes = 718 sqft / 2116.44 pounds

MONUMENTAL



1 Box = 3 Paneelen = 2.035 m² / 21.65 kg
1 box = 3 panels = 21.90 sqft / 47.72 pounds



48 Boxen = 97.68 m² / 1039 kg
48 boxes = 1051.43 sqft / 2291 pounds

OAK / WALNUT



1 Box = 5 Paneele = 1.332 m² / 16 kg
1 box = 5 panels = 14.33 sqft / 35.27 pounds



40 Boxen = 53.27 m² / 640 kg
40 boxes = 573.40 sqft / 1410.8 pounds

GRAND FINISH

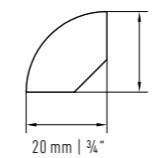

Viertelstab / Quarterround
1 Box = 25 Stk.
1 box = 25 pcs.

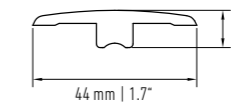

Übergangprofil / Transition profile
1 Box = 10 Stk.
1 box = 10 pcs.

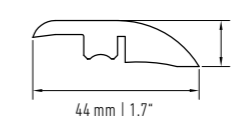

Ausgleichprofil / Reducer
1 Box = 7 Stk.
1 box = 7 pcs.

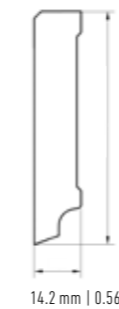

Sockelleiste / Skirting board
1 Box = 10 Stk.
1 box = 10 pcs.

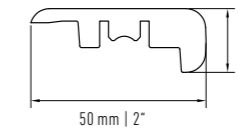

Treppenkante / Stairnose
1 Box = 6 Stk.
1 box = 6 pcs.



GARANTIERT
SCHWEIZER HOLZ



Das Zeichen für verantwortungsvolle
Waldwirtschaft
Fragen Sie nach FSC®-
zertifizierten Produkten



SWISS KRONO AG
Willisauerstrasse 37
6122 Menznau
Schweiz

T +41 41 494 94 94

F +41 41 494 94 49

info@swisskrono.ch

www.swisskrono.ch

Contact Flooring: T+ 41 41 494 95 60 | F +41 41 494 95 69
flooring@swisskrono.ch | grand-selection.ch